

Wheeler[®]

DELTA SERIES[™]

ULTRA AR-15 Armorer's Kit

Instruction #I059906

Revision: E



STOP!

**AMERICAN
OUTDOOR**
BRANDS CORPORATION

1800 North Route Z
Columbia, MO 65202

**Have an issue with this product?
DO NOT USE IT OR RETURN IT
BEFORE CONTACTING CUSTOMER SERVICE.**

Please contact Customer Service
by filling out the form on the contact page of our website at
www.wheelertools.com/ or call us at: 1-833-784-5523.

NOT WARRANTED AGAINST MISUSE, ABUSE, OR COMMERCIAL USE.

Limited Warranty

For complete warranty terms and conditions, please visit www.wheelertools.com/warranty-info.html
or contact Customer Service at 1-833-784-5523.

INDEX

- 3..... AR-15 Adjustable Receiver Link
- 3..... Pivot Pin and Roll Pin Installation Tool
- 4..... AR Armorer's Vise Instructions
- 7..... Upper Vise Block Clamp with Gas Tube Alignment Tool
- 9..... Delta Ring Tool
- 10... AR-15 Combo Tool with Torque Wrench
- 10... Strap Wrench
- 11... AR-15 Bore Guide
- 12... Bore Brush, .22 Cal
- 12... Bolt Carrier Brush
- 12... Chamber Brush
- 12... Magazine/Upper Receiver Brush
- 13... AR-15 Armorer's Bench Block
- 14... AR-15 Roll Pin Install Tool Kit
- 16... AR Front Sight Tool
- 16... Bolt Catch Install Punch Kit



- A. AR Armorer's Vise
- B. AR-15 Combo Tool
- C. Torque Wrench
- D. Upper Vise Block Clamp with Gas Tube Alignment Tool
- E. Maintenance Mat with Exploded View AR-15
- F. Pivot Pin and Roll Pin Installation Tool
- G. AR Front Sight Tool
- H. Delta Ring tool
- I. Strap Wrench
- J. AR-15 Bore Guide
- K. AR-15 Adjustable Receiver Link
- L. Bore Brush, .22 Cal
- M. Bolt Carrier Brush
- N. Chamber Brush
- O. Magazine/Upper Receiver Brush
- P. Nylon Brush Handle
- Q. Double-ended General Cleaning Brush
- R. Cleaning Pick Set
- S. Custom Fitted Carrying Case
- T. AR Armorer's Bench Block
- U. AR Bolt Catch Install Punches
- V. AR Trigger Guard Install Tool
- W. AR Roll Pin Install Punches
- X. Non-marring hammer

AR-15 Adjustable Receiver Link

The Adjustable Receiver Link is designed to maintain and secure the open position of your AR Upper and Lower assembly during cleaning and maintenance.

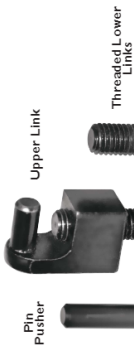

Installation:

1. Determine which threaded lower link is needed for your particular application and thread it into the Upper Link. A minimum of three revolutions of thread engagement is recommended.
2. Position your AR lower into a secure holding device. We recommend the Delta Series AR-15 Mag well Vise Block included on the Armorer Vise.
3. Depress the rear take down pin and open the receiver forward.
4. Install the Upper Link engaging the hinge pin boss of your AR Upper Receiver.
5. Make the desired length adjustments to the Lower Link and align it with your lower receiver take down pin and press the pin fully through the lower.



Pivot Pin and Roll Pin Installation Tool



Pivot Pin Instructions:

1. Insert tool into receiver, aligning hole in tool with spring cavity in receiver.
2. Insert Spring and Detent into the cavity through the hole in the tool.
3. Using pin, depress Detent and rotate 90°
4. Carefully slide Pivot Pin into Lower Receiver, pushing tool out simultaneously.



Roll Pin Instructions:

1. Place Roll Pin into hole in Lower Receiver.
2. Place the Blind Hole in the side of the tool onto the roll pin and carefully tap into place.
3. Once started, use the hole on the end of the tool to drive the roll pin into place.
4. Use the narrow tip to finish driving the roll pin flush with the Receiver.

AR-15 AR Armors Vise Instructions

The AR Armors Vise was designed to accommodate nearly any position needed to service an AR-15. Each component is capable of multiple positions that enable you to configure an AR for the task at hand.

- The base can be used with the existing rubber feet or be permanently mounted to a bench top surface. (bench top fasteners not included)
- Each "RISER" has two positions that provide an additional 1" placement. 14.25" – 16.25" from center to center.



16.25"

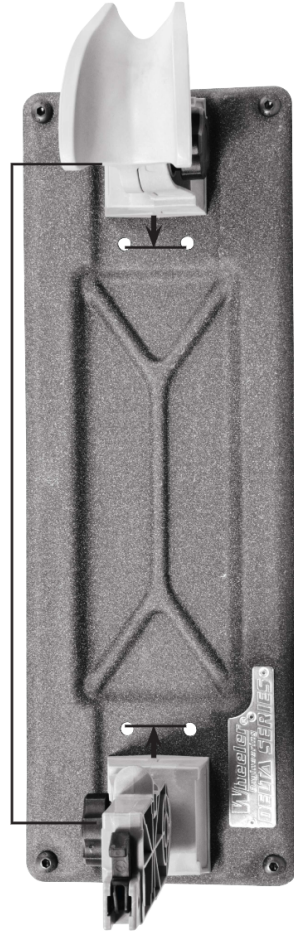

- The rear AR-15 Mag well support is capable of 15° incremental adjustments
 - Integral Hammer Stop
 - Integral Bolt service station

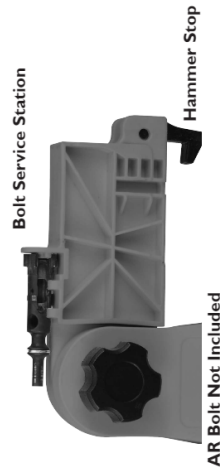

AR Bolt Not Included

- The Forend Support can rotate in 15° increments and accommodate a range of barrel or forend diameters up to 2.3"

How to use the Bolt Service Station and Hammer Stop

1. Before attempting to remove the ejector, you must first remove the extractor. This can be done by simply pushing the extractor pin through the body of the bolt. (See Photo D)

TIP: use the #550-067 pin punch from the Wheeler Deluxe Screw Driver Kit.

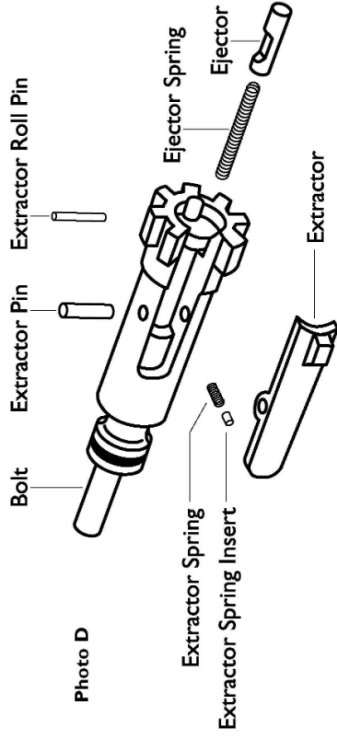

2. Once the Extractor has been removed, insert the bolt in such a fashion that the locking lugs straddle the bolt lug retaining rib located on the side of the Vise Block. (See Photo E)

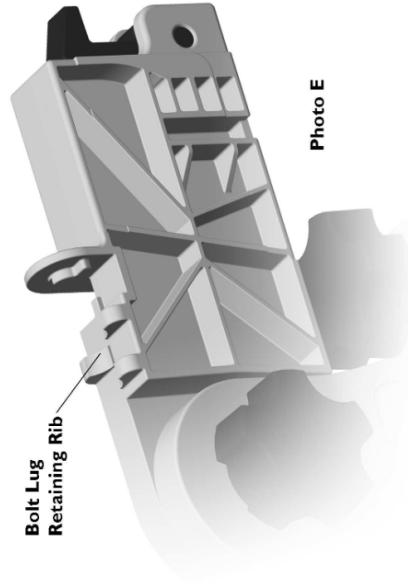

3. Carefully position the bolt as shown in Photo F, rotating slightly clockwise to allow the bolt lugs to pass over the bolt-lug retaining rib as mentioned above.

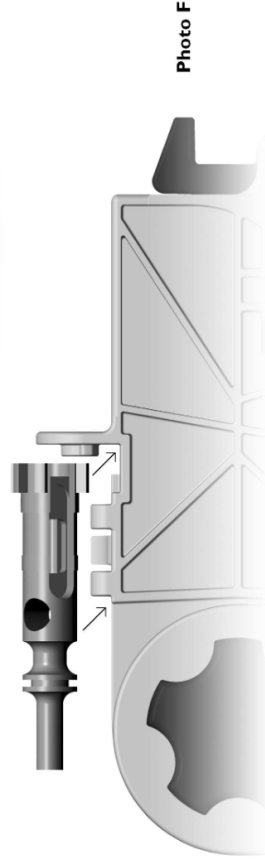

How to use the Bolt Service Station and Hammer Stop

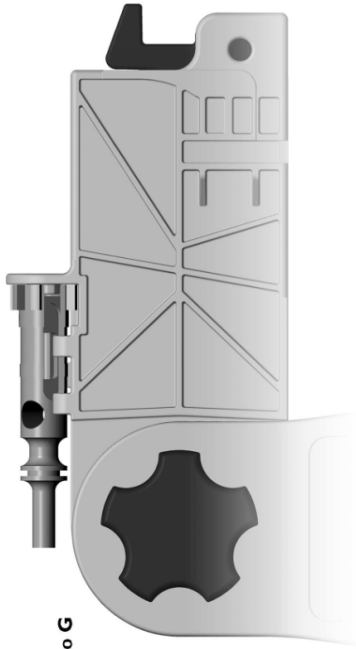

Photo G

- Once the bolt is in position, push the bolt forward depressing the ejector spring and turn counter-clockwise until the bolt-lugs stop. (See Photos G & H)
- The bolt is now held hands free to remove the ejector roll pin. **TIP:** use the #1 I-520 pin punch from the Wheeler Deluxe Screw Drive Kit.

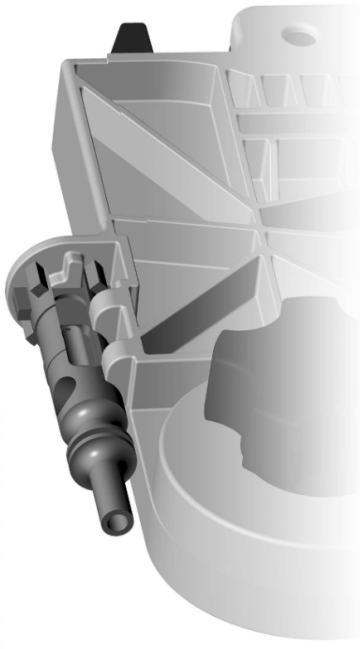

Photo H

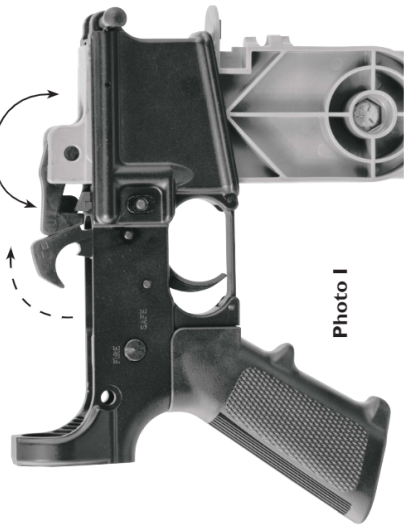

Photo I

HAMMER STOP FUNCTION:

The Vise Block includes a Hammer Stop to protect the lower receiver while dry firing.

- Once the receiver is installed onto the Vise Block, simply rotate the hammer block into position. (See Photo I)

AR-15 Upper Vise Block Instructions

The Delta Series AR-15 Upper Vise Block is optimized for left hand and right hand Mil Spec A2 upper receivers with carry handles, as well as flattop style receivers. Other AR-15 variants may be adapted with special attention to potentially non-conforming surfaces or features. The Block allows you to safely clamp on to your AR-15 upper receiver in a vise holding it securely without twisting, crushing or marring the finish.

Usage Instructions:

- Place the receiver insert into the rear of the upper receiver; if your receiver is equipped with a dust cover door, the receiver insert is designed to lock in place when the dust door is closed. If your receiver is not equipped with a dust cover, the receiver insert will not be secure until clamping pressure has been applied.
 - Place Receiver Insert into rear of Upper Receiver.
 - Vise Block Ribs
 - Close dust cover BEFORE closing vise block.
- Open the Upper Vise block on a flat surface with the ribs facing the bench. Position your receiver from either direction and align the front pivot pin lug in the recessed pocket.
- Close the Upper Vise Block and inspect for proper positioning. There should be a gap of approximately 1/16" opposite of the hinge. **A gap in excess of 1/4" may suggest the upper receiver is not Mil Spec and clamping in a vise may damage the Upper Vise Block.** The Wheeler Engineering Delta Series Upper/Pic Rail Vise Block (#156888) will work for these uppers.

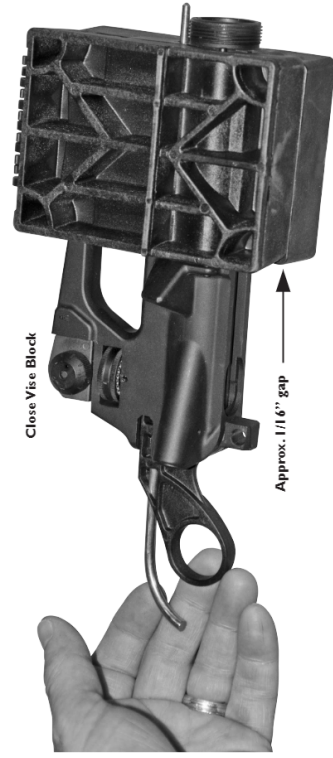
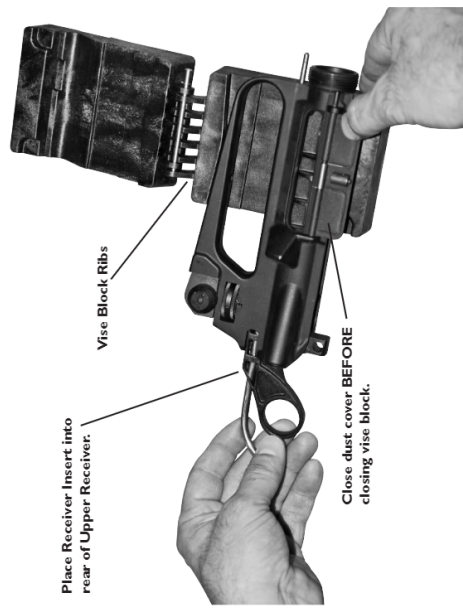

Usage Instructions:

4. The Upper Vise Block is designed to rest on top of the vise jaws using the two ribs along the outside surfaces.

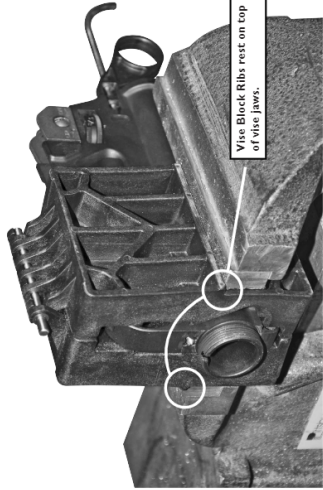

5. Once the Upper Vise Block has been securely clamped into a bench top vise, your upper receiver is ready for all your maintenance needs.

Installing a Barrel:

1. After Steps 1-5 of the Usage Instructions have been completed you are ready to install a barrel on your receiver.

NOTE: Inspect and clean the threads of both the receiver and the barrel nut prior to assembly. Apply a quality anti-seize compound to the receiver threads. This will enable proper torque to be achieved as well as help prevent thread seizing.

2. Pay careful attention to the position of the Upper Vise Block while assembling the barrel. It may be necessary to apply additional clamping force to maintain position.
3. Thread the barrel nut on the receiver while holding the barrel in place.



4. Use AR-15 Combo Tool with Torque Wrench by placing hardened steel barrel nut pins onto barrel nut. Place Torque Wrench into 1/2" drive and apply proper barrel nut torque. (**Mil-Spec 30-80 FT-LBS**)



5. Once you have applied the proper barrel nut torque, use the gas tube alignment rod to check for proper barrel nut alignment. Make necessary adjustments until the gas tube alignment rod passes through the receiver and into the barrel nut freely.



Delta Ring Tool

USAGE INSTRUCTION:

The Delta Ring Tool can be used to remove handguards by inserting the tab on the end of the tool into the magazine well, then squeezing the tool's handles together around the Delta Ring while pushing down. This applies pressure to the Delta Ring, holding it open to allow removal of the handguards. (See photo for reference)

- Makes removing mil-spec AR-15 and M16 handguards easy by compressing the Delta Ring with one hand
- 100% vinyl coating protects the guns finish from damage but is very durable
- Custom formed wire fits securely around Delta Ring for perfect fit
- Welded steel bracket for durability even with stuck or broken Delta Rings



AR-15 Combo Tool with Torque Wrench

Perform most of your AR-15 service needs with a single tool. An innovative layered and laminated stamped steel construction makes the Delta Series AR-15 Combo Tool the most durable AR tool available. This construction method allows the use of hardened steel barrel nut pins designed to hold up to heavy torque requirements. A cut out for a 1/2" drive allows the tool to be used with a torque wrench or ratchet driver. Profiles for buffer tube lock nut and 3/4" flash hider are included.

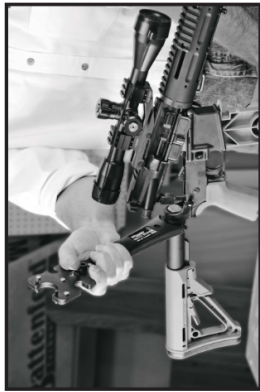

The notched end is specifically designed to grab the Receiver Extension Nut and tighten it securely without crushing the nut or buffer tube.

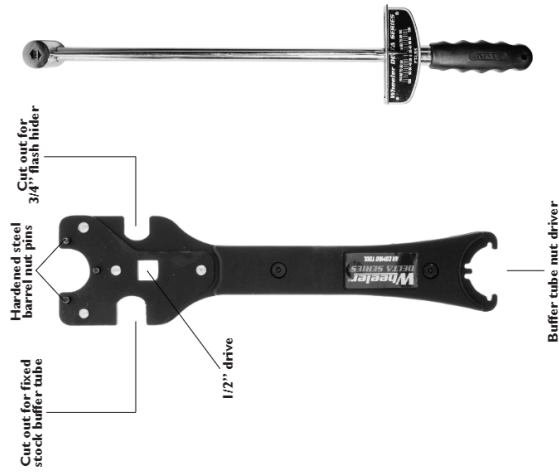

This heavy-duty strap wrench gives you plenty of leverage to tighten or remove screw-on free-float handguard tubes. It can loosen tubes that are "frozen" by corrosion between the barrel nut and guard. The large adjustable strap of reinforced rubber wraps securely around any diameter handguard, with no risk of scratching the finish or crushing the tube.

Strap Wrench

AR-15 Bore Guide

The Delta Series AR-15 Bore Guide will help protect the bore and action of your rifle by properly aligning the cleaning rod and reducing solvent overflow. Cleaning without a bore guide can allow the rod to "bow" and rub or gouge chamber and throat of the bore causing real damage and loss of accuracy. Keeping the rod properly aligned not only protects your barrel, it directs the force exerted on the cleaning rod handle allowing tight patches to be pushed more easily.



INSTRUCTIONS:

1. Remove the bolt carrier assembly and charging handle from the upper and insert the Bore Guide.
2. Rotate the Bore Guide until the solvent port is facing directly upward.
3. Close dust cover to lock the Bore Guide into position.
4. After cleaning, rotate the Bore Guide approximately 90 degrees clockwise until the solvent port is aligned with the dust cover side of the upper and pull the guide to the rear. This will open the dust cover and release the Bore Guide.

2 sets of chemical-resistant O-Rings to accommodate varying sizes of receiver inner diameters & are non-marring to inside of receiver

Ramp feature allows you to unlock dust cover by rotating the bore guide 90° clockwise in receiver

Most conveniently located solvent port of any AR-15 bore guide on the market

Dust cover locking groove keeps bore guide from pulling out of receiver unintentionally



O-RINGS:

The chemical resistant O-rings will retain the Bore Guide in uppers that do not have dust covers. Two sets of O-rings are provided; the black colored set will produce a tighter fit, the green set will produce a looser fit. The two grooves at the very rear of the Bore Guide are the "storage position" for the spare set of O-rings. A very small flat bit screwdriver works well to remove the O-rings.

AR-15 Complete Brush Kit

The Wheeler Delta Series AR-15 Complete Brush Set is specifically designed for cleaning your AR-15. The brushes are made of a high quality stiff nylon, spun around steel cores for added stability. The brushes feature an 8-32 thread that fit on the included cleaning handle or any 8-32 cleaning rod. The brush set has every brush you need to clean your rifle, plus everything you need to keep your magazines clean and running reliably.



Chamber Brush



Upper Receiver Magazine Brush



.22 Caliber Bore Brush



Bolt Carrier Brush

- The Brush Set Includes:
- Magazine/Upper Receiver Brush with Magazine Takedown Tool
 - Bolt Carrier Brush
 - Chamber Brush
 - .22 Caliber Bore Brush
 - Handle for action and chamber cleaning

Magazine takedown tool removes butt plates quickly and easily

AR-15 Armorer's Bench Block



WARNING: ALWAYS WEAR SAFETY GLASSES WHEN MAINTAINING OR ASSEMBLING FIREARMS.



For assembling a complete Lower Receiver, installing triggers, grips, or other parts, support the Lower on the block as shown.



To install the Bolt Catch Roll Pin, support the Lower Receiver in the block as shown

To assemble an Upper Receiver, support it in the block as shown.

Note: The block will hold the Forward Assist with the spring compressed to aid in installing the roll pin. (Be sure that the Forward Assist is aligned correctly when installing the pin.)



To install or replace the Charging Handle Latch, support it in the block as shown



To assemble or disassemble a Front Sight Base with taper pins, or to install or remove a Gas Tube Roll Pin, support it in the block as shown.

Note: Taper pins can only be installed from the right side and removed from the left side. "PINS IN" and "PINS OUT" are marked on the block, be sure to use the correct side.

AR-15 Roll Pin Install Tool Kit

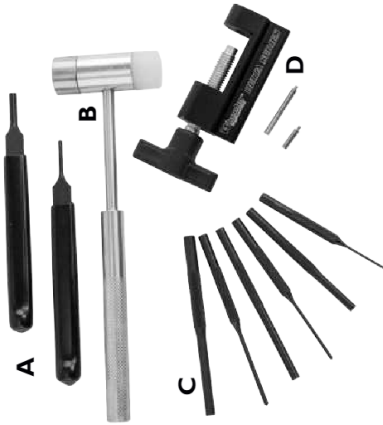

- A. Bolt Catch Install Tool Kit
- B. Two Sided Hammer
- C. 6 Steel punches
- D. AR Trigger Guard Install Tool

Punch Size	Roll Pin
1/16	A1 sight drum roll pin
	A2 windage drum roll pin
	Bolt ejector roll pin
	F/A pawl roll pin
5/64	Gas tube roll pin
3/32	Bolt catch roll pin
1/8	F/A retaining roll pin
	Trigger guard roll pin

Each punch size includes a starter punch and a install punch. Easily start roll pin installation with the roll pin starter punch. Finish roll pin installation with the roll pin install punch.

AR Trigger Guard Install Tool

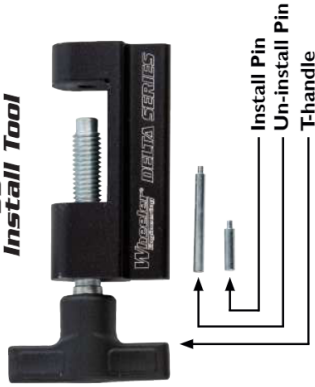

1. Using the t-handle unscrew the trigger guard tool until there is space to seat the un-install pin inside of the threaded shaft. (Photo A)
2. Align the un-install pin with the trigger guard roll pin (Photo B) and tighten using the t-handle until the roll pin is removed from trigger guard. (Photo C)

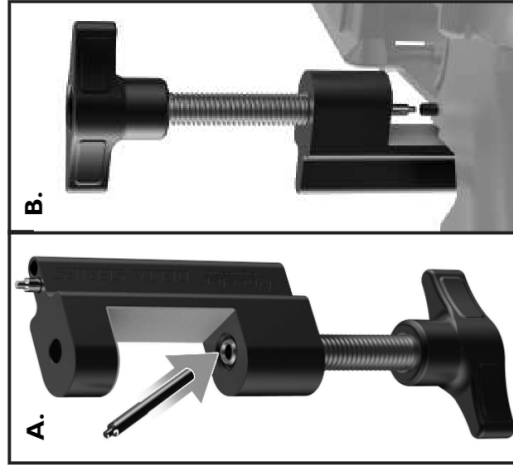

Trigger Guard Removal



3. Use the un-install pin to gently depress the detent on the opposite side of the trigger guard and remove trigger guard. (Photo D)

Trigger Guard Installation

1. Install detent side of trigger guard first.
2. Using the t-handle unscrew the trigger guard tool until there is space to seat the install pin inside of the threaded shaft. (Photo E)
3. Align the install pin with the trigger guard roll pin and the roll pin hole opening. (Photo F)
4. Put the un-install pin through the back hole to align the trigger guard hole to the AR lower receiver hole. (Photo G)
5. Tighten using the t-handle until the roll pin is installed into the trigger guard. (Photo H)

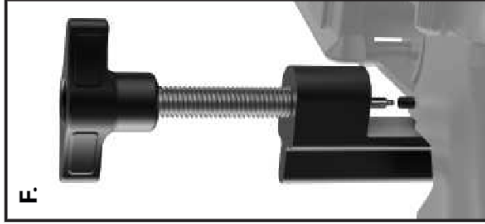

NOTE: Some after-market trigger guards use an allen screw instead of a roll pin. Reference the trigger guard manufacturer's installation instructions.



AR-15 Bolt Catch Install Punch Kit

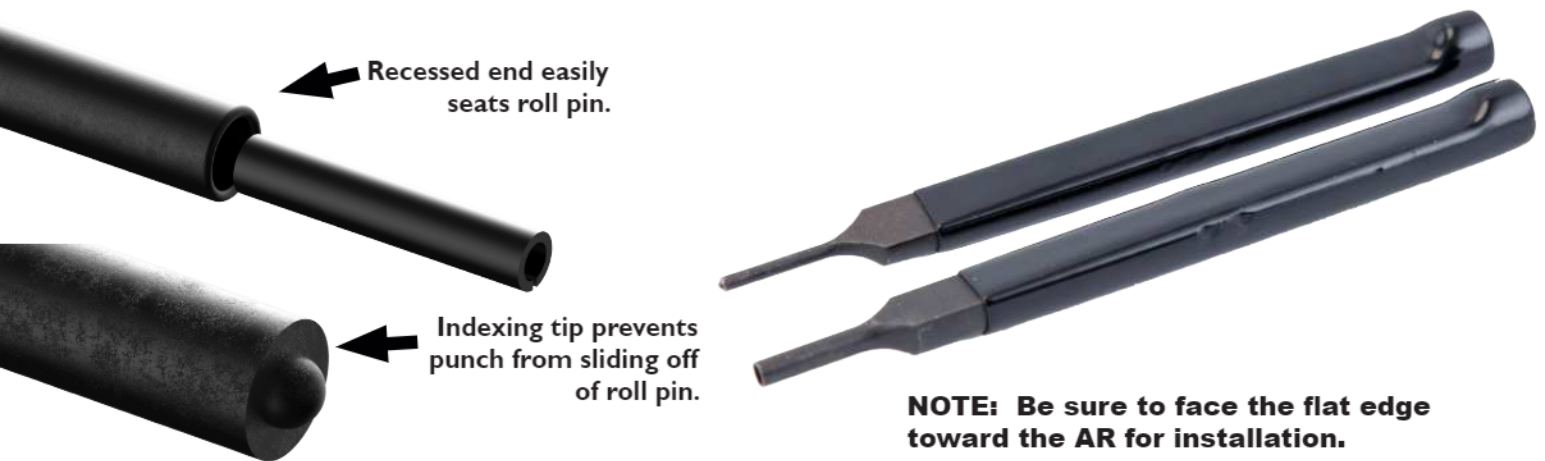

Recessed end easily seats roll pin.

Indexing tip prevents punch from sliding off of roll pin.

NOTE: Be sure to face the flat edge toward the AR for installation.



Easily start roll pin installation with roll pin starter punch.



Finish roll pin installation with roll pin install punch.

AR Front Sight Tool

- Install and adjust standard Mil-Spec A2 front sights on AR-15, M16 and M4
- Can be used with any 1/4" hex driver
- Key ring for storage serves as a handle
- Black zinc plated steel

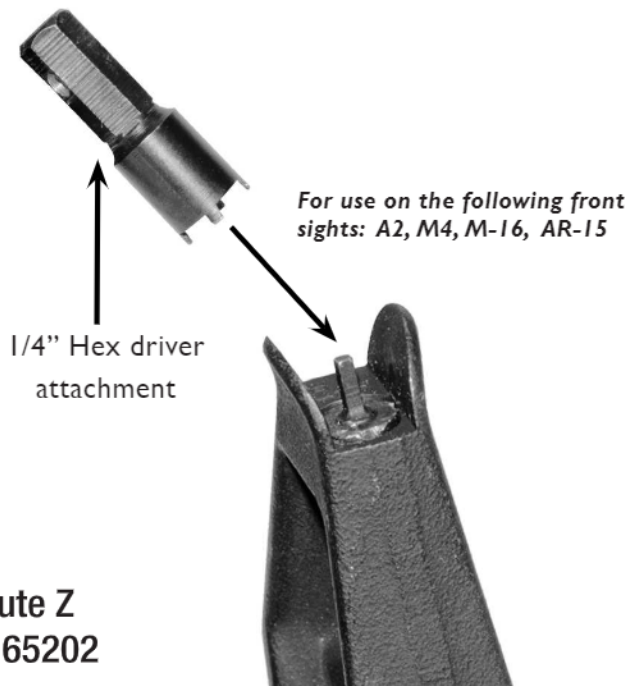

For use on the following front sights: A2, M4, M-16, AR-15

1/4" Hex driver attachment